

INDUSTRY 4.0 APPLICATIONS



Optimum STU
R&D CENTER

- BARCODE - QR CODE
- CHECKWEIGHERS
- IMAGE PROCESSING
- PLC -P/C INGETRATION (MRP)
- RFID - BEACON
- DATA ANALYSIS
- AGV
- SPECIAL PROJECTS JUST FOR YOUR NEEDS
- EMBEDDED SYSTEMS



Box Filling - Palletizing - Stretch Wrapping System

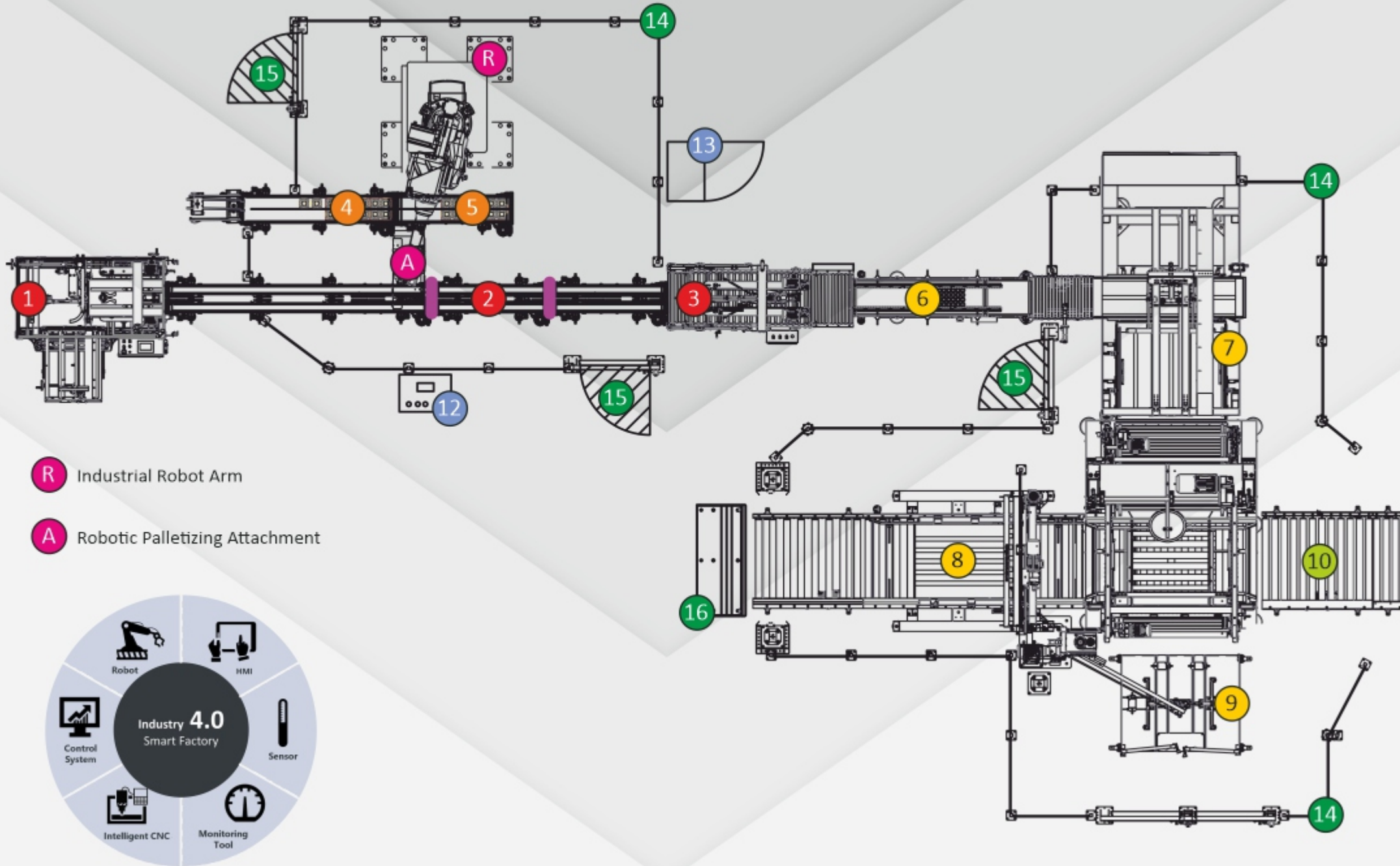



Optimum STU

R&D CENTER



ROBOTIC APPLICATIONS



CONVEYOR SYSTEMS



STRETCH WRAPPING SYSTEMS



BOX FILLING SYSTEMS



PALLETIZING



R&D DEVELOPMENT

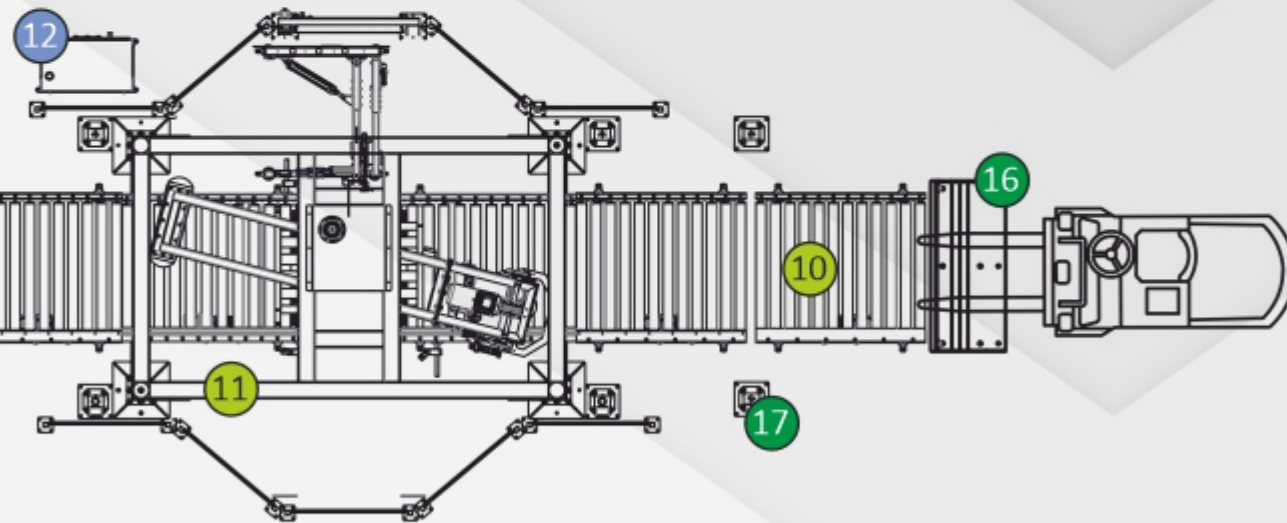

- 1 Carton Erector
- 2 Box Prep.-Box Filling-Box Outlet Conv.
- 3 Box Closer & Bottom Sealer
- 4 Divider & Product Former
- 5 Product Preparing Layer
- 6 Product Infeed Conveyor
- 7 Palletizer
- 8 Pallet Magazine
- 9 Separator Magazine & Robot
- 10 Pallet Transport Conveyor
- 11 Stretch Wrapping System
- 12 Kiosk Panels
- 13 Electrical & Automation Cabinet
- 14 Safety Fences
- 15 Safety Doors
- 16 Forklift Barriers
- 17 Light Barriers

Carton Erector - Closer - Sealer Systems



SCAN QR CODE
FOR THE
VIDEOS



15 Box/Min.
OBOX E.15-A1

CARTON ERECTOR & BOTTOM SEALER

25 Box/Min
OBOX C.25-C1

BOX CLOSER & SEALER

25 Box/Min
OBOX ALT.25

TOP & BOTTOM SEALER

Robotic Box Filling & Palletizing Systems

Robotic Application's Advantages

- Standardized production
- High efficiency
- Minimum space requirements
- Easy integration with your current production line.
- Highly adaptable for changing products
- Multiple operations can be handled with one robot
- Protects worker's health with the capability of handling heavy & hazardous materials
- The systems are built with great quality & technology to work for years without any problems.
- Palletizing systems protect the workers from the injuries caused by repetitive works.



SCAN QR CODE
FOR THE
VIDEOS



Robotic Palletizing Systems



Policarbon 5 Gallon Robotic Palletizing
Palletizing & De-Palletizing



4 Gallon Glass with Baskets Robotic Palletizing
Palletizing & De-Palletizing

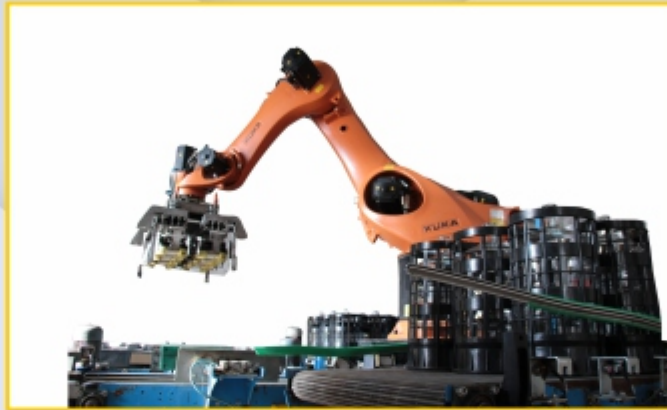

Policarbon 5 Gallon Rack Loading & Unloading
with Rack Cleaning Option



PET 5 Gallon Robotic Palletizing



Complete Layer Robotic Palletizing
(Can be used for any type of product.)



Shrink Bundled Products Robotic Palletizing

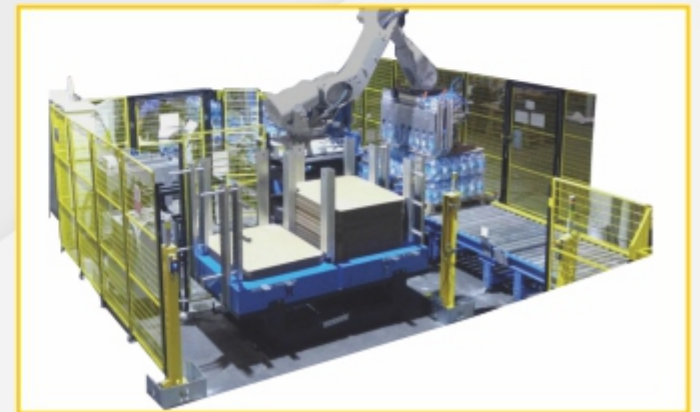

Kraft, Fabric & Plastic Sack Palletizing (5kg - 50 kg)



Robotic Hybrid Palletizing (Box & 5 Gallon)



Multi-Purpose Fork Palletizing

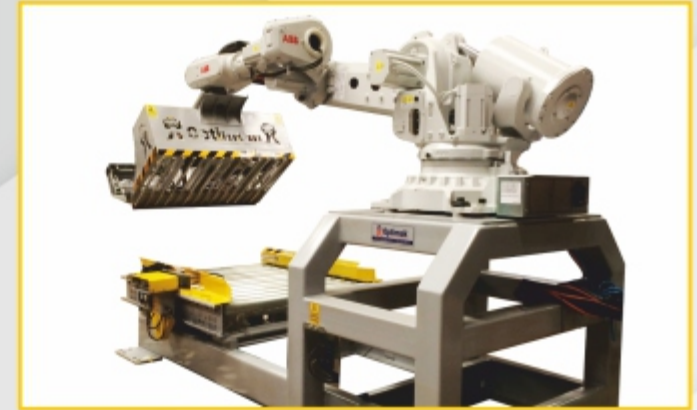

Robotic Box Palletizing



Vacuum Gripper Palletizing - De-palletizing
Suitable for every kind of product & packaging

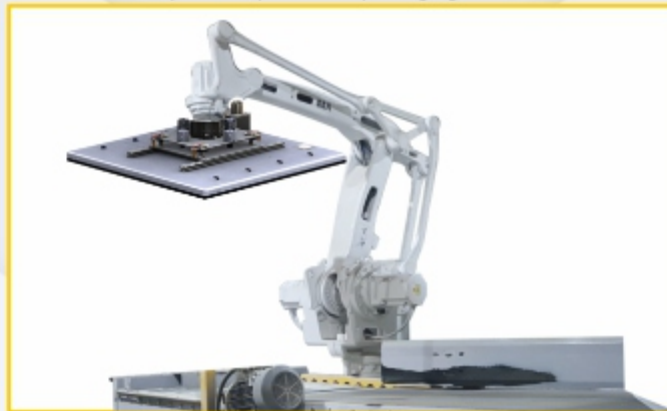

Robotic Test Lab With Various Attachments
For testing our customers products to find best attachments



Robotic Attachments for Material Handling

19 Lt. Carboy (5 Gallon) Gripper



- 19 Lt. PET Carboy (5 Gallon PET) Palletizing
- 15 Lt. Glass Carboy (4 Gallon Glass) & Plastic Basket Palletizing - De-palletizing
- 19 Lt. PC Carboy (5 Gallon PC) Palletizing - De-palletizing

Bag Handling Gripper



- Kraft, Fabric & Plastic Bag Palletizing (5 kg. - 50 kg.)
- Pet Food, Fertilizer, Construction Chemicals, Detergents, Flour etc.

Box Handling Gripper

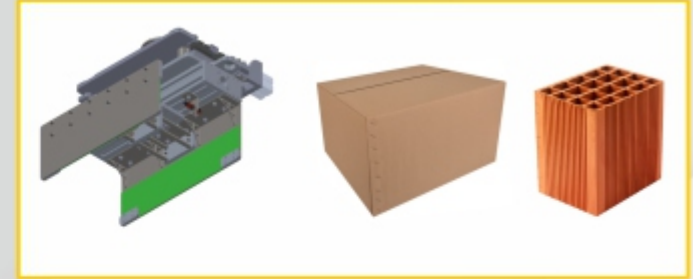

- Corrugated Carton Box Palletizing
- Water, Biskuit, Sugar, Cleaning Products, Cosmetics etc.
- Every product comes with a box can be palletized.

Tin Can Gripper



- 1lt. - 20 lt. Tin Can Palletizing - De-palletizing
- Edible Oil, Machine Oil, Cleaning Products, Various Asidic & Alkaline Products, Various Chemicals etc.

Plastic Jerrycan Gripper

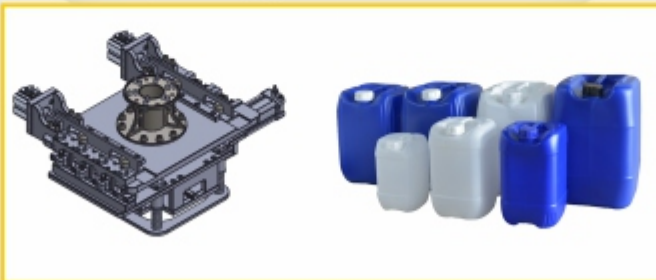

- 1lt. - 25 Lt. Plastic Jerrycan Palletizing - De-palletizing
- Edible Oil, Machine Oil, Cleaning Products, Various Asidic & Alkaline Products, Various Chemicals etc.

Multi-Purpose Fork Gripper



- Corrugated Carton Box, Shrink Bundled Products etc.
- Can be used with various products, specially used for perishable delicate packaging

Shrink Bundle Gripper

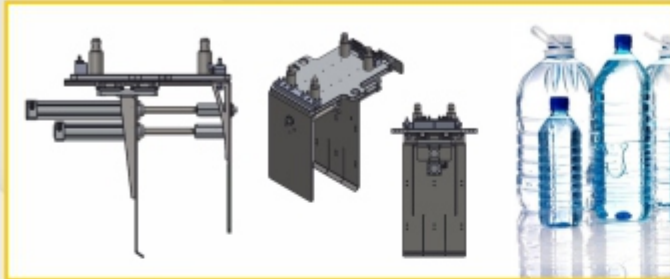

- Shrink Bundle Palletizing
- Water, Oil, Various Drinks etc.

Bucket Gripper

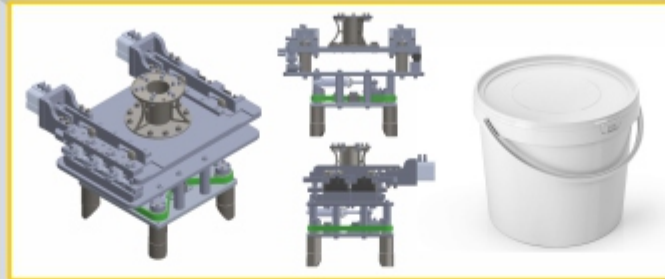

- 2.5 Kg. - 25 Kg. Bucket Palletizing - De-palletizing
- Yogurt, Paint, Various Chemicals, Glue etc.

Vacuum Gripper



- Box, Carton, Separator, Tin Can, Kraft Paper Wrap etc.

Magnetic Gripper

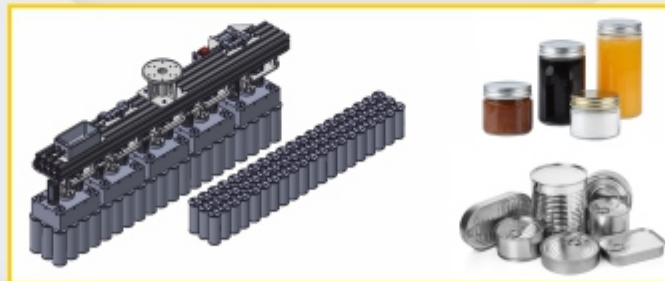

- For metal lids & Canned products
- Tomato Paste, Tuna, Jam Jars, Canned Drinks etc.

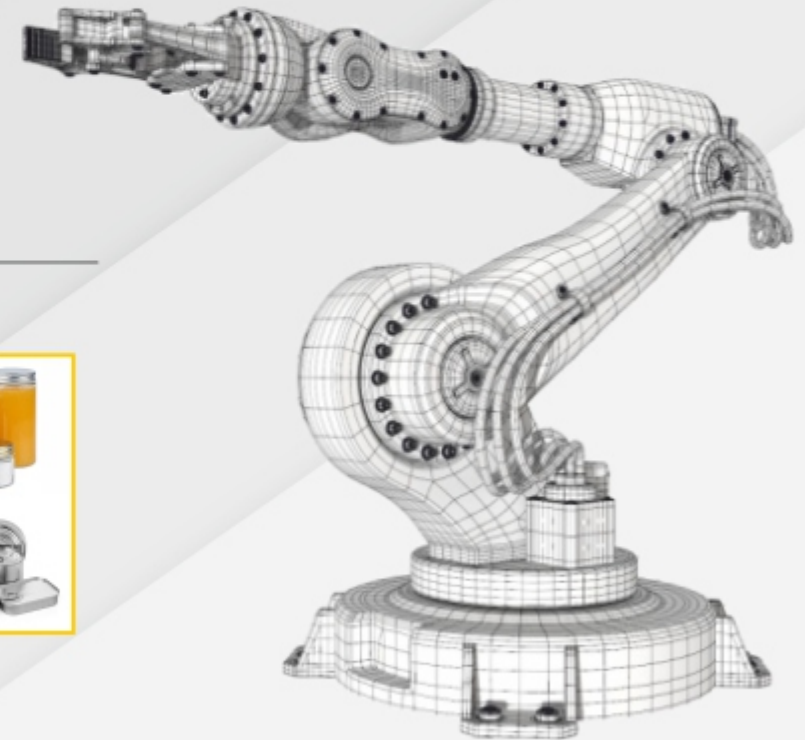

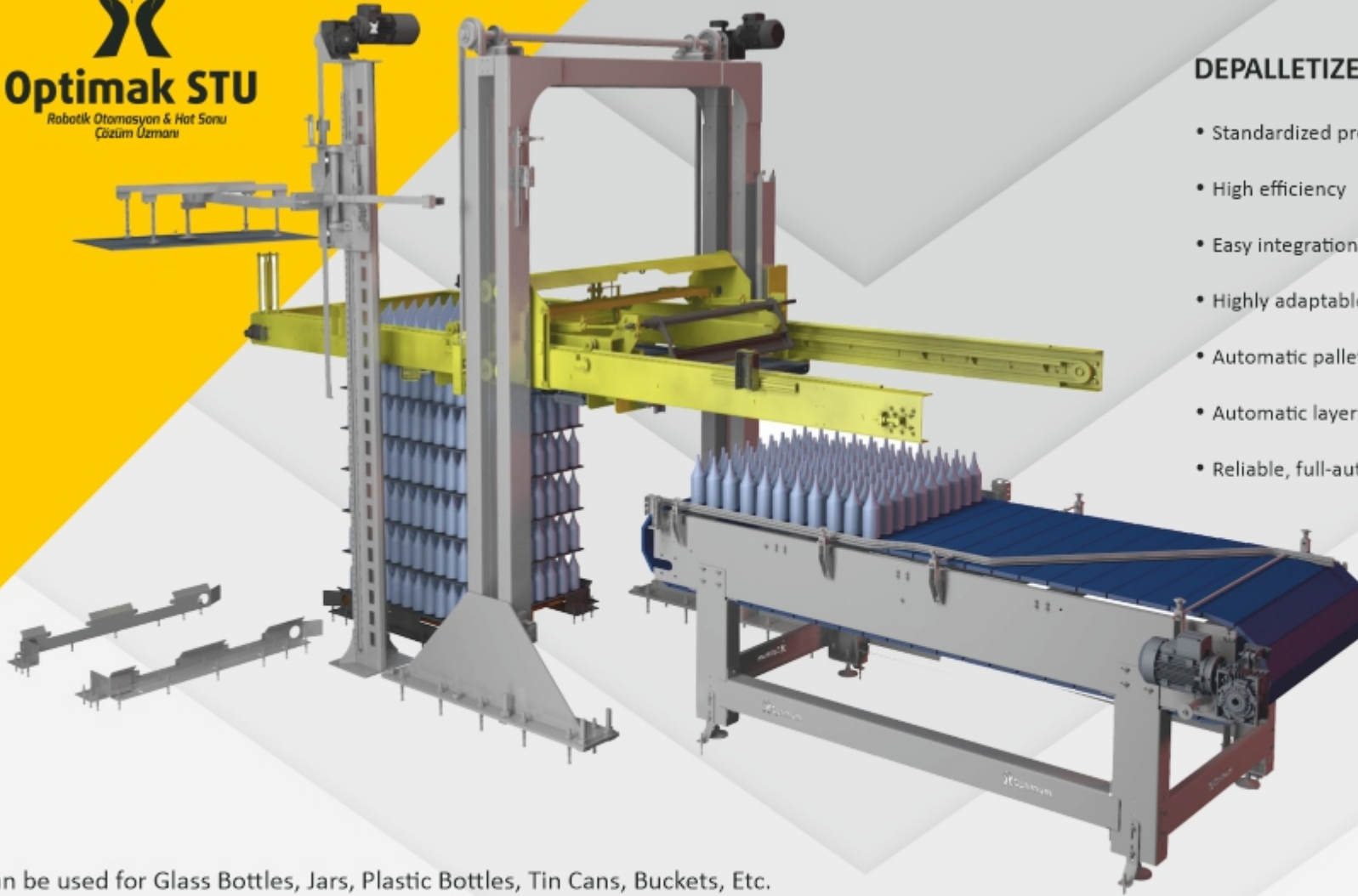

DEPALLETIZER's Advantages & Specs

- Standardized product feeding rate to your filling machinery
- High efficiency
- Easy integration with your current production line.
- Highly adaptable for changing products
- Automatic pallet height perception with sensors
- Automatic layer separator removal robot
- Reliable, full-automatic de-palletizing system

Can be used for Glass Bottles, Jars, Plastic Bottles, Tin Cans, Buckets, Etc.



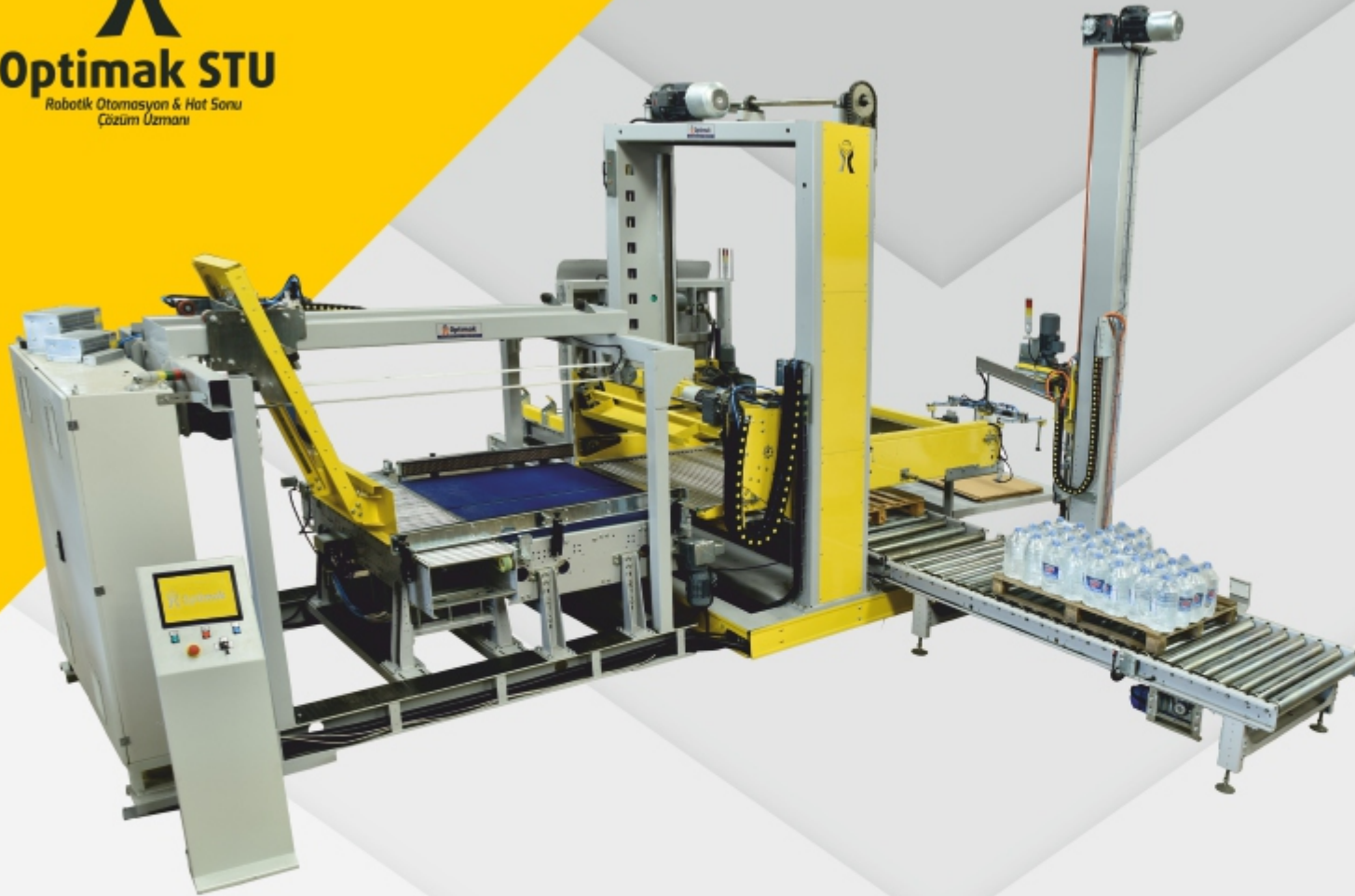

SCAN QR CODE
FOR THE
VIDEOS

Optional Equipments for Palletizers & Stretch Wrappers

PALLET MAGAZINE



SEPARATOR ROBOT



ROBOBOX



BIND, SEAL & CUT



Spinner Series
Horizontal S. Wrappers

- Spinner 450 Up to 350 mm width
- Spinner 1000 Up to 950 mm width
- Spinner 1500 Up to 1.350 mm width
- Spinner 1800 Up to 1.800 mm width



TOP SHEET LAYER



SEMI-AUTOMATIC
STRETCH ROLL TRANSFER
MACHINE



BAR CODE - QR CODE
APPLICATORS



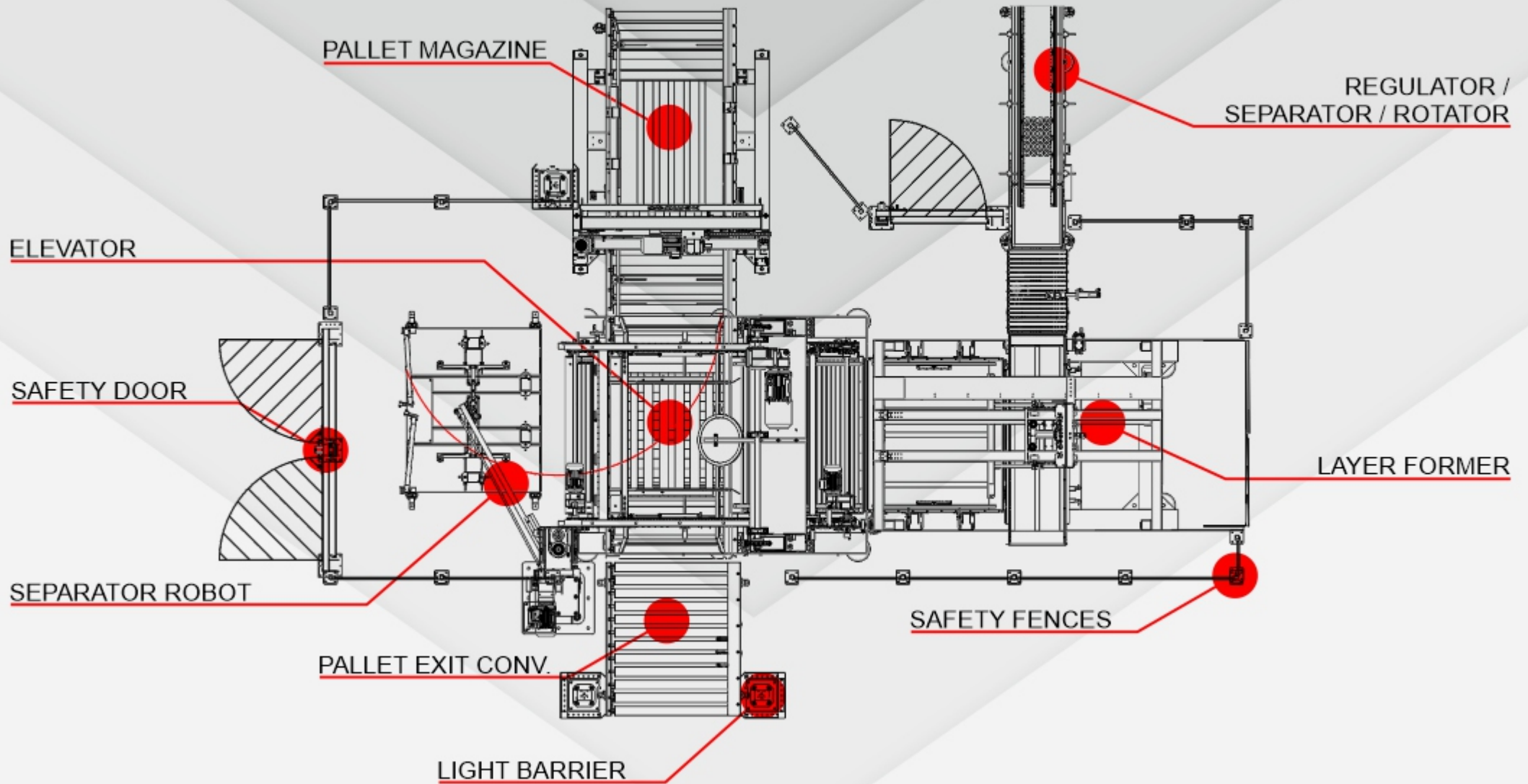

Stretch Wrapping Systems



SCAN
QR CODE
FOR THE
VIDEOS

20 pallet/Hour
OWRAP T20-A2



20 pallet/Hour
OWRAP TR20-A2



20 pallet/Hour
OWRAP ARM 20-A2



30 pallet/Hour
OWRAP ARM 30



40 pallet/Hour
OWRAP ARM 40



60 pallet/Hour
OWRAP ARM 60



20 pallet/Hour
OWRAP CON 20

- 5 Celsius Degrees



30 pallet/Hour
OWRAP CON 30

- 25 Celsius Degrees





OWRAP ARM Stretch Wrapping System

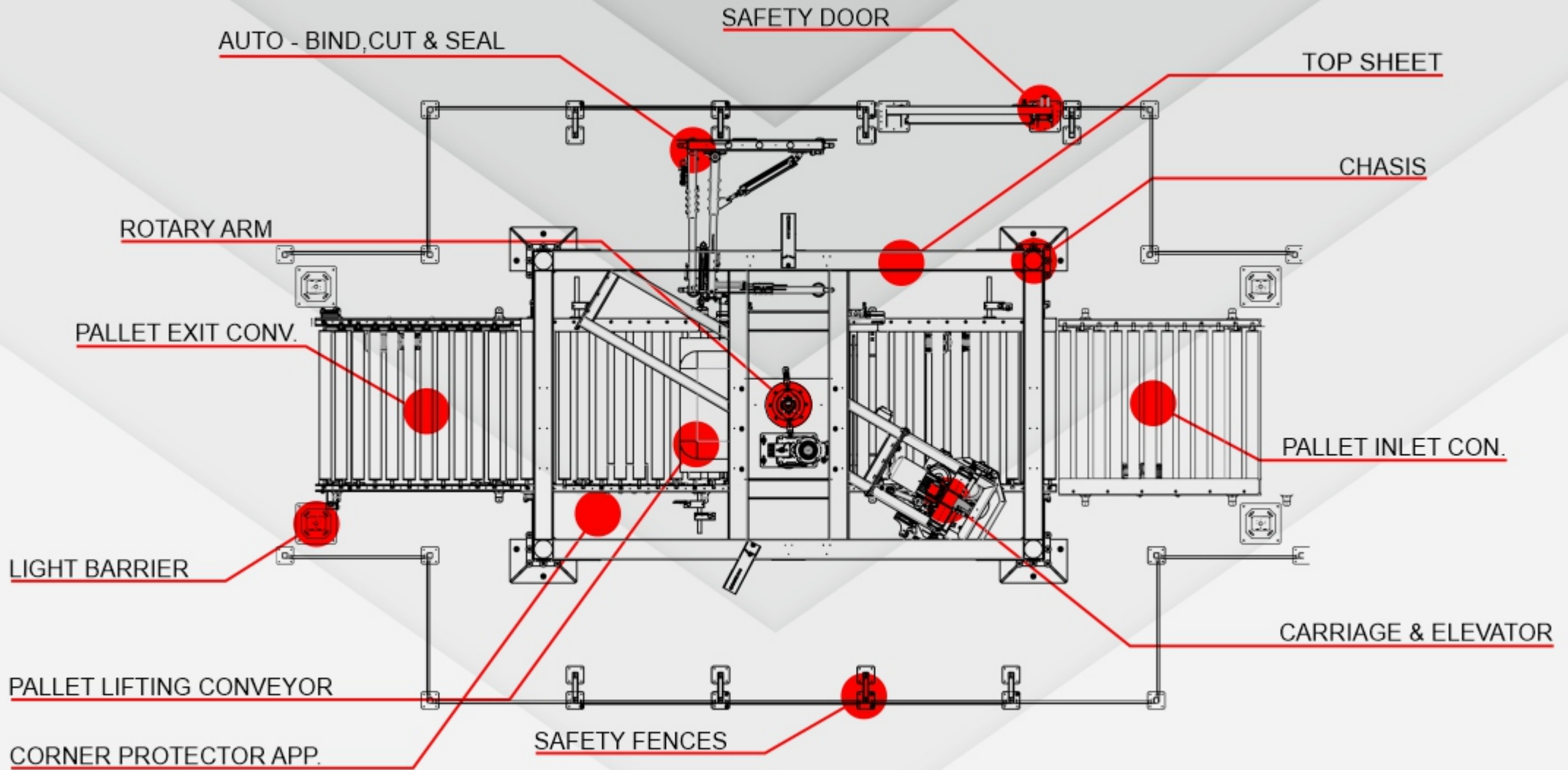

Pallet Transport Conveyors

Chain Conveyor



Rotary Chain Conveyor

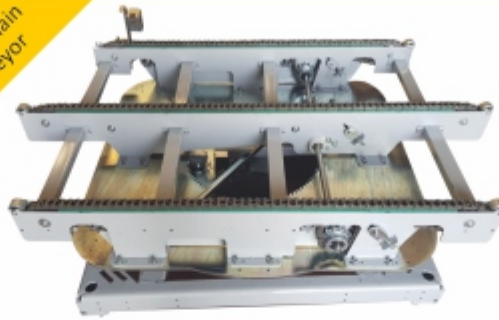

Modular Belt Conveyor



Roller Conveyor



Rotary Roller Conveyor



Ground Roller Conveyor



Shuttle Rotary Conveyor



Transpallet Ground Conveyor



Shuttle Pallet Transport Conveyor



Pallet Transport Conveyors

Modular Belt
Rotary Conveyor



Cartesian
Rotary Conveyor



Transpallet
Lift Conveyor



Cartesian Conveyor



Pallet Elevators

Pallet Transport
Elevator Systems



SCAN
QR CODE
FOR THE
VIDEOS

Product Transport Conveyors

Inox Belt Conveyor



PVC Belt Conveyor

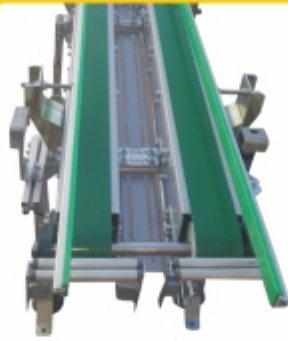

Roller Accumulation Conveyor



Beaded Accumulation Conveyor



90° Acetal Belt Conveyor



90° Short Turn Modular Belt Conveyor



Modular Belt Conveyor

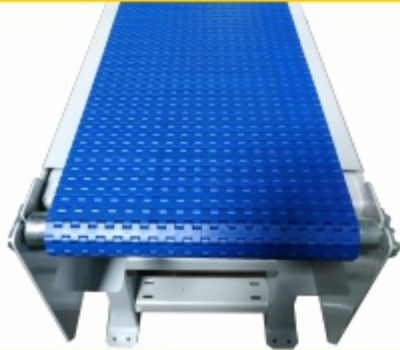

Acetal Tab Conveyor



PVC Belt Conveyor



Safety Systems

Light Barrier



Safety Gate



Sliding Safety Gate



Forklift Barrier



Safety Fences



Safety Door

